

Stainless Steel Ball Valve (SBV)

Features

- 2 piece ball valve
- Basic design and manufacturing according to ANSI B16.34
- Adjustable packing gland, bottom-loaded blowout proof stem
- NPT threaded ends complied with ANSI B1.20.1
- Inspection and tested according to API598
- Applicable medium: water, oil, gas, and acid

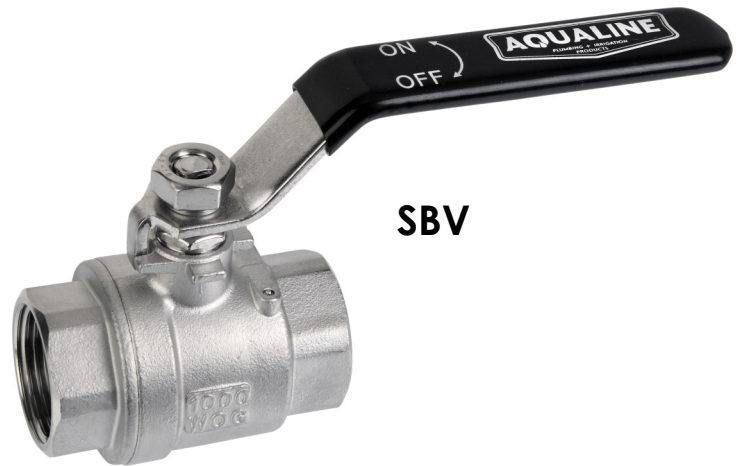
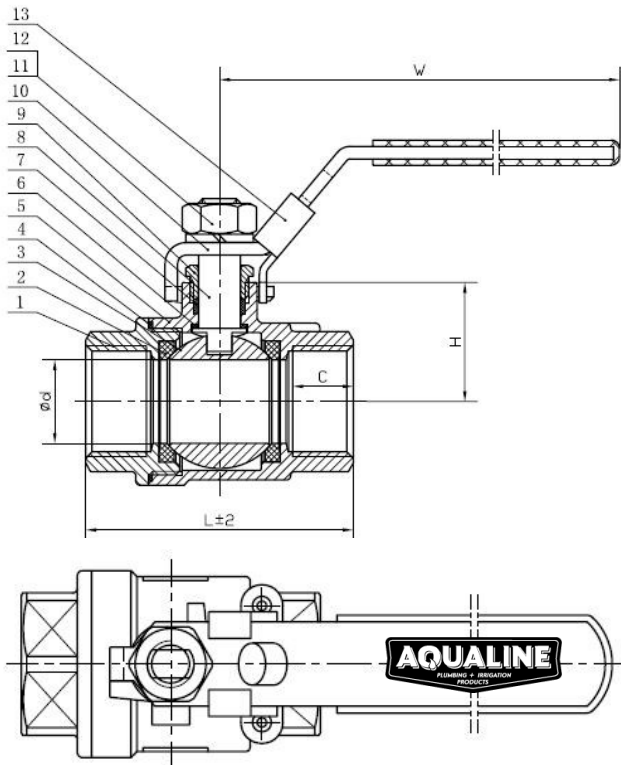

SBV

Material Specification

No.	Parts	Materials
1	End cap	ASTM A351 CF8
2	Seat	PTFE
3	Ball	ASTM A276 304
4	Gasket	PTFE
5	Body	ASTM A351 CF8
6	Stem gasket	PTFE
7	Packing	PTFE
8	Packing gland	ASTM A276 304
9	Stem	ASTM A276 304
10	Handle	SS201 +PE
11	Spring washer	SS201
12	Handle nut	SS201
13	Handle lock	SS201

Dimensions (mm)

Size	Ød	L	H	W	C
1/4"	10	48	20.50	90	11
3/8"	10	48	20.50	90	11
1/2"	15	56	26	98	12
3/4"	20	62	29	115	13
1	25	72	34	125	16
1-1/4"	32	87	42	148	16
1-1/2"	38	96	48.50	168	16
2"	49	108	56	168	16

Main Technical Parameter

Normal Pressure		4.0	MPa
Test Pressure	Shell test pressure	6.0	MPa
	Tightness test	4.4	
	Gas-tightness test	0.6	
Max working temperature		-20 ~ 100	°C